

**MTEL General Curriculum Mathematics**  
**Multiple Choice Practice Questions**  
**Debra K. Borkovitz, Wheelock College**  
**Summer 2011**

**Note:** I used the official objectives and sample test to construct these questions, but I make no promises that they accurately reflect what's actually on the real test. Feel free to copy, distribute, and modify for any educational, non-profit use. See [terms of use](#). I am working on an interactive version of this test; see [here](#) for updates.

**Subarea I: Numbers and Operations (41%)**

**Objective 0016: Understand the number system and the concept of place value.**

1) Which of the following is equal to eleven billion four hundred thousand?

- A) 11,400,000
- B) 11,000,400,000
- C) 11,000,000,400,000
- D) 11,400,000,000

2) Which of the following is equal to one million three hundred thousand?

- A)  $1.3 \times 10^6$
- B)  $1.3 \times 10^9$
- C)  $1.03 \times 10^6$
- D)  $1.03 \times 10^9$

3) In each expression below,  $N$  represents a negative integer. Which expression could have a negative value?

- A)  $N^2$
- B)  $6 - N$
- C)  $-N$
- D)  $6 + N$

4) A class is using base-ten block to represent number. A large cube represents 1000, a flat represents 100, a rod represents 10, and a little cube represents 1. Which of these is not a correct representation for 2,347?

- A) 23 flats, 4 rods, 7 little cubes
- B) 2 large cubes, 3 flats, 47 rods
- C) 2 large cubes, 34 rods, 7 little cubes
- D) 2 large cubes, 3 flats, 4 rods, 7 little cubes

5) Which of the following is an irrational number?

- A)  $\sqrt[3]{8}$
- B)  $\sqrt{8}$
- C)  $\frac{1}{8}$
- D)  $-8$

6) Here are some statements:

- I) 5 is an integer
- II)  $-5$  is an integer
- III) 0 is an integer

Which of the statements are true?

- A) I only
- B) I and II only
- C) I and III only
- D) I, II, and III

7) Which of the lists below contains only irrational numbers?

A)  $\pi$ ,  $\sqrt{6}$ ,  $\sqrt{\frac{1}{2}}$

B)  $\pi$ ,  $\sqrt{9}$ ,  $\pi+1$

C)  $\frac{1}{3}$ ,  $\frac{5}{4}$ ,  $\frac{2}{9}$

D)  $-3$ ,  $14$ ,  $0$

8) If  $x$  is an integer, which of the following must also be an integer?

A)  $\frac{x}{2}$

B)  $\frac{2}{x}$

C)  $-x$

D)  $\sqrt{x}$

9) In January 2011, the national debt was about 14 trillion dollars and the US population was about 300 million people. Someone reading these figures estimated that the national debt was about \$5,000 per person. Which of these statements best describes the reasonableness of this estimate?

A) It is too low by a factor of 10

B) It is too low by a factor of 100

C) It is too high by a factor of 10

D) It is too high by a factor of 100

10) A typical red blood cell has diameter  $6 \times 10^{-6}$  meters, and a typical pin head has diameter 2 millimeters. Which number below is closest to the number of red blood cells needed to form a line as long as the diameter of the typical pin head?

A) 30

B) 300

C) 3,000

D) 30,000

11) Use the expression below to answer the question that follows.

$$\frac{(4 \times 10^3) \times (3 \times 10^4)}{6 \times 10^6}$$

Which of the following is equivalent to expression above?

- A) 2
- B) 20
- C) 200
- D) 2000

12) Use the expression below to answer the question that follows.

$$\frac{(7,154) \times (896)}{216}$$

Which of the following is the best estimate of the expression above?

- A) 2,000
- B) 3,000
- C) 20,000
- D) 30,000

13) Use the expression below to answer the question that follows.

$$3 \times 10^5 + 2.2 \times 10^2$$

Which of the following is closest to the expression above?

- A) Five million
- B) Fifty thousand
- C) Three million
- D) Thirty thousand

14) Use the expression below to answer the question that follows.

$$\frac{(155) \times (6,124)}{977}$$

Which of the following is the best estimate of the expression above?

- A) 100
- B) 200
- C) 1,000
- D) 2,000

**0017 Understand integers, fractions, decimals, percents, and mixed numbers.**

15) Which of the lists below is in order from least to greatest value?

- A)  $\frac{1}{2}$ ,  $\frac{1}{3}$ ,  $\frac{1}{4}$ ,  $\frac{1}{5}$
- B)  $\frac{1}{3}$ ,  $\frac{2}{7}$ ,  $\frac{3}{8}$ ,  $\frac{4}{11}$
- C)  $\frac{1}{4}$ ,  $\frac{2}{5}$ ,  $\frac{2}{3}$ ,  $\frac{4}{5}$
- D)  $\frac{7}{8}$ ,  $\frac{6}{7}$ ,  $\frac{5}{6}$ ,  $\frac{4}{5}$

16) Which of the lists below is in order from least to greatest value?

- A)  $-0.044$ ,  $-0.04$ ,  $0.04$ ,  $0.044$
- B)  $-0.04$ ,  $-0.044$ ,  $0.044$ ,  $0.04$
- C)  $-0.04$ ,  $-0.044$ ,  $0.04$ ,  $0.044$
- D)  $-0.044$ ,  $-0.04$ ,  $0.044$ ,  $0.04$

17) Use the table below to answer the question that follows:

Store	Discount
A	Buy two pounds, get the third pound half price
B	15% off per pound
C	$\frac{1}{4}$ off of three pounds
D	\$1 off per pound

Gordon wants to buy three pounds of nuts. Each of the stores above ordinarily sells the nuts for \$4.99 a pound, but is offering a discount this week. At which store can he buy the nuts for the least amount of money?

- A) Store A
- B) Store B
- C) Store C
- D) Store D

18) Which of the numbers below is the decimal equivalent of  $\frac{3}{8}$ ?

- A) 0.38
- B) 0.125
- C) 0.375
- D) 0.83

19) Which of the numbers below is a fraction equivalent to  $0.\overline{6}$ ?

- A)  $\frac{4}{6}$
- B)  $\frac{3}{5}$
- C)  $\frac{6}{10}$
- D)  $\frac{1}{6}$

20) Which of the numbers below is not equivalent to 4%?

A)  $\frac{1}{25}$

B)  $\frac{4}{100}$

C) 0.4

D) 0.04

21) Given that 10 cm is approximately equal to 4 inches, which of the following expressions models a way to find out how many inches are equivalent to 350 cm?

A)  $350 \times \left(\frac{10}{4}\right)$

B)  $350 \times \left(\frac{4}{10}\right)$

C)  $(10-4) \times 350$

D)  $(350-10) \times 4$

22) What fraction of the area of the picture below is shaded?

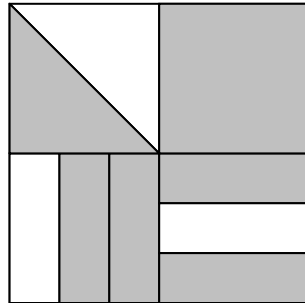

A)  $\frac{17}{24}$

B)  $\frac{3}{4}$

C)  $\frac{2}{3}$

D)  $\frac{25}{36}$

23) The picture below shows identical circles drawn on a piece of paper. The rectangle represents an index card that is blocking your view of  $\frac{3}{5}$  of the circles on the paper. How many circles are covered by the rectangle?

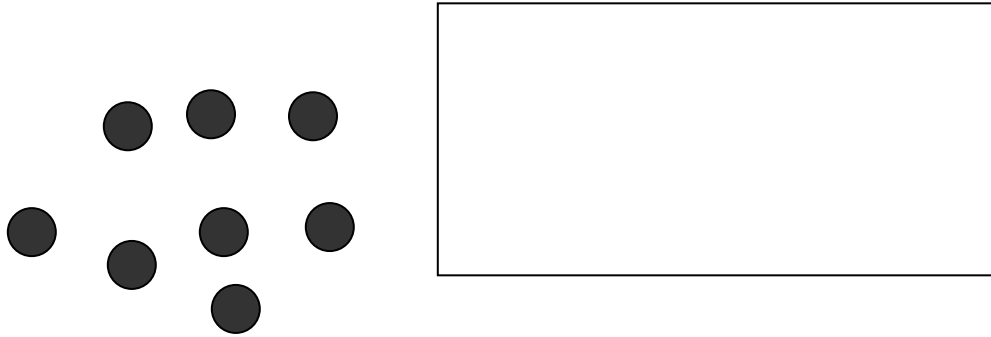

- A) 4
- B) 5
- C) 8
- D) 12

24) Below are several expressions

I.  $\frac{1}{2} + \frac{1}{3}$

II. .400000

III.  $\frac{1}{5} + \frac{1}{5}$

IV. 40%

V. 0.25

VI.  $\frac{14}{35}$

Which of the lists below includes all of the above expressions that are equivalent to  $\frac{2}{5}$ ?

- A) I, III, V, VI
- B) III, VI
- C) II, III, VI
- D) II, III, IV, VI

25) Below is a portion of a number line.

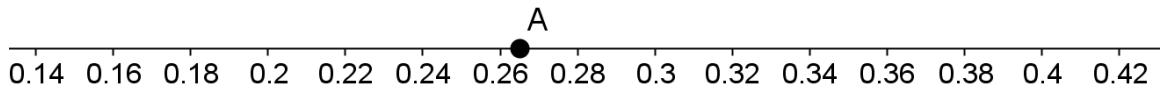

Point A is one-quarter of the distance from 0.26 to 0.28. What number is represented by point A?

- A) 0.26
- B) 0.2625
- C) 0.265
- D) 0.27

26) Below is a portion of a number line:

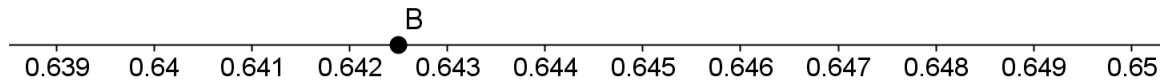

Point B is halfway between two tick marks. What number is represented by Point B?

- A) 0.645
- B) 0.6421
- C) 0.6422
- D) 0.6425

**0018 Understand and apply principles of number theory.**

27) Exactly one of the numbers below is a prime number. Which one is it?

- A) 511
- B) 517
- C) 519
- D) 521

28) The letters A, and B represent digits (possibly equal) in the ten digit number  $x = 1,438,152,A3B$ . For which values of A and B will  $x$  be divisible by 12, but not by 9?

- A)  $A = 0, B = 4$
- B)  $A = 7, B = 2$
- C)  $A = 0, B = 6$
- D)  $A = 7, B = 6$

29) The prime factorization of  $n$  can be written as  $n = pqr$ , where  $p, q$ , and  $r$  are distinct prime numbers. How many factors does  $n$  have, including 1 and itself?

- A) 3
- B) 5
- C) 6
- D) 8

30) What is the greatest common factor of 540 and 216?

- A)  $2^2 \cdot 3^3$
- B)  $2 \cdot 3$
- C)  $2^3 \cdot 3^3$
- D)  $2^2 \cdot 3^2$

31) What is the least common multiple of 540 and 216?

- A)  $2^5 \cdot 3^6 \cdot 5$
- B)  $2^3 \cdot 3^3 \cdot 5$
- C)  $2^2 \cdot 3^3 \cdot 5$
- D)  $2^2 \cdot 3^2 \cdot 5^2$

32) Elena is going to use a calculator to check whether or not 267 is prime. She will pick certain divisors, and then find 267 divided by each, and see if she gets a whole number. If she never gets a whole number, then she's found a prime. Which of the following is true so that Elena can be sure she has a prime number?

- A) Elena needs to check all the natural numbers from 2 to 266 as potential divisors.
- B) Elena needs to check all the primes from 2 to 266 as potential divisors.
- C) Elena needs to check all the primes from 2 to 133 as potential divisors.
- D) Elena needs to check all the primes from 2 to  $\sqrt{267}$  as potential divisors.

33) Suppose  $P$  is a prime number that divides 240. Which of the following must be true?

- A)  $P$  divides 30
- B)  $P$  divides 48
- C)  $P$  divides 75
- D)  $P$  divides 80

34) The chairs in a large room can be arranged in rows of 18, 25, or 60 with no chairs left over. If  $C$  is the smallest possible number of chairs in the room, which of the following inequalities does  $C$  satisfy?

- A)  $C \leq 300$
- B)  $300 < C \leq 500$
- C)  $500 < C \leq 700$
- D)  $C > 700$

35) The least common multiple of 60 and  $N$  is 1260. Which of the following could be the prime factorization of  $N$ ?

- A)  $2 \cdot 5 \cdot 7$
- B)  $2^3 \cdot 3^2 \cdot 7$
- C)  $3 \cdot 7$
- D)  $3^2 \cdot 5 \cdot 7$

**0019 Understand operations on numbers.**

36) The following story situations model  $12 \div 3$ :

I) Jack has 12 cookies, which he wants to share equally between himself and two friends. How many cookies does each person get?

II) Trent has 12 cookies, which he wants to put into bags of 3 cookies each. How many bags can he make?

III) Cicely has \$12. Cookies cost \$3 each. How many cookies can she buy?

Which of these questions illustrate the same model of division, either partitive (partitioning) or measurement (quotative)?

- A) I and II
- B) I and III
- C) II and III
- D) all three model the same meaning of division

37) Here is a student's work on several multiplication problems:

$$\begin{array}{r}
 12 \\
 \times 38 \\
 \hline
 816 \\
 \underline{360} \\
 1176
 \end{array}
 \qquad
 \begin{array}{r}
 76 \\
 \times 8 \\
 \hline
 5648
 \end{array}
 \qquad
 \begin{array}{r}
 41 \\
 \times 22 \\
 \hline
 82 \\
 \underline{820} \\
 902
 \end{array}$$

For which of the following problems is this student likely to get the correct solution, even though he is using an incorrect algorithm?

- A)  $52 \times 22$
- B)  $16 \times 24$
- C)  $31 \times 23$
- D)  $41 \times 32$

38) Use the samples of a student's work below to answer the question that follows:

This student divides fractions by first finding a common denominator, then dividing the numerators.

$$\begin{array}{l}
 \frac{2}{3} \div \frac{3}{4} \longrightarrow \frac{8}{12} \div \frac{9}{12} \longrightarrow 8 \div 9 = \frac{8}{9} \\
 \frac{2}{5} \div \frac{7}{20} \longrightarrow \frac{8}{20} \div \frac{7}{20} \longrightarrow 8 \div 7 = \frac{8}{7} \\
 \frac{7}{6} \div \frac{3}{4} \longrightarrow \frac{14}{12} \div \frac{9}{12} \longrightarrow 14 \div 9 = \frac{14}{9}
 \end{array}$$

Which of the following best describes the mathematical validity of the algorithm the student is using?

- A) It is not valid. Common denominators are for adding and subtracting fractions, not for dividing them.
- B) It got the right answer in these three cases, but it isn't valid for all rational numbers.
- C) It is valid if the rational numbers in the division problem are in lowest terms.
- D) It is valid for all rational numbers.

39) Use the samples of a student's work below to answer the question that follows:

$$\frac{2}{3} \times \frac{3}{4} = \frac{4 \times 2}{3 \times 3} = \frac{8}{9}$$

$$\frac{2}{5} \times \frac{7}{7} = \frac{7 \times 2}{5 \times 7} = \frac{2}{5}$$

$$\frac{7}{6} \times \frac{3}{4} = \frac{4 \times 7}{6 \times 3} = \frac{28}{18} = \frac{14}{9}$$

Which of the following best describes the mathematical validity of the algorithm the student is using?

- A) It is not valid. It never produces the correct answer.
- B) It is not valid. It produces the correct answer in a few special cases, but it's still not a valid algorithm.
- C) It is valid if the rational numbers in the multiplication problem are in lowest terms.
- D) It is valid for all rational numbers.

40) Which of the following values of  $x$  satisfies the inequality  $|(x+2)^3| < 3$ ?

- A)  $x = -3$
- B)  $x = 0$
- C)  $x = -4$
- D)  $x = 1$

41) If  $|x+2| > 3$ , which of the following describes all possible values of  $x$ ?

- A)  $x > 1$  or  $x < -5$
- B)  $x > 0$
- C)  $x > 1$
- D)  $-5 < x < 1$

42) Which of the following inequalities describes all values of  $x$  with  $\frac{x}{2} \leq \frac{x}{3}$ ?

- A)  $x < 0$
- B)  $x \leq 0$
- C)  $x > 0$
- D)  $x \geq 0$

43) The expression  $7^{-4} \cdot 8^{-6}$  is equal to which of the following?

A)  $\frac{8}{(56)^4}$

B)  $\frac{64}{(56)^4}$

C)  $\frac{1}{8 \cdot (56)^4}$

D)  $\frac{1}{64 \cdot (56)^4}$

44) The expression  $8^3 \cdot 2^{-10}$  is equal to which of the following?

A) 2

B)  $\frac{1}{2}$

C) 16

D)  $\frac{1}{16}$

45. Here is a method that a student used for subtraction:

$$\begin{array}{r} 16 \\ 8 \cancel{6} 4 \\ - 3 \cancel{2} 8 3 \\ \hline 5 8 1 \end{array}$$

Which of the following is correct?

A) The student used a method that worked for this problem and can be generalized to any subtraction problem.

B) The student used a method that worked for this problem and that will work for any subtraction problem that only requires one regrouping; it will not work if more regrouping is required.

C) The student used a method that worked for this problem and will work for all three-digit subtraction problems, but will not work for larger problems.

D) The student used a method that does not work. The student made two mistakes that cancelled each other out and was lucky to get the right answer for this problem.

46) Which of the following is equivalent to  $\left(\frac{3}{4} \times \frac{2}{3} - \frac{2}{8}\right) \div 2$ ?

A)  $\frac{1}{2}$

B)  $\frac{1}{4}$

C)  $\frac{1}{8}$

D)  $\frac{1}{16}$

47) On a map the distance from Boston to Detroit is 6 cm, and these two cities are 702 miles away from each other. Assuming the scale of the map is the same throughout, which answer below is closest to the distance between Boston and San Francisco on the map, given that they are 2,708 miles away from each other?

- A) 21 cm
- B) 22 cm
- C) 23 cm
- D) 24 cm

48) A solution requires 4 ml of saline for every 7 ml of medicine. How much saline would be required for 50 ml of medicine?

- A)  $28\frac{4}{7}$  ml
- B)  $28\frac{1}{4}$  ml
- C)  $28\frac{1}{7}$  ml
- D) 87.5 ml

49) Which of the following points (A, B, C, D) is closest to  $\frac{34}{135} \times \frac{53}{86}$ ?

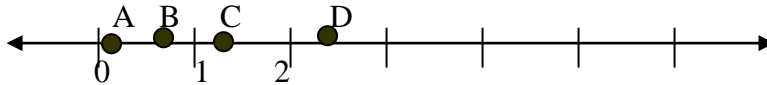

50) Which of the following numbers is a rounded off solution to  $12.345 \div 0.12247$ ?

- A) 0.1008
- B) 1.008
- C) 10.08
- D) 100.8

**Subarea II: Functions and Algebra (22%)**

**0020 Understand algebra as generalized arithmetic**

51) Some children explored the diagonals in  $2 \times 2$  squares on pages of a calendar. They conjectured that the sum of the diagonals is always equal; in the example below,  $8+16=9+15$ .

June						
S	M	T	W	R	F	S
			1	2	3	4
5	6	7	8	9	10	11
12	13	14	15	16	17	18
19	20	21	22	23	24	25
26	27	28	29	30		

Which of the equations below could best be used to explain why the children's conjecture is correct?

- A)  $8x+16x=9x+15x$
- B)  $x+(x+2)=(x+1)+(x+1)$
- C)  $x+(x+8)=(x+1)+(x+7)$
- D)  $x+8+16=x+9+15$

52) Here is a number trick:

- 1) Pick a whole number
- 2) Double your number.
- 3) Add 20 to the above result.
- 4) Multiply the above by 5
- 5) Subtract 100
- 6) Divide by 10

The result is always the number that you started with! Suppose that number is  $N$ . Which of the equations below best demonstrates that the result of the trick is also  $N$ ?

- A)  $N * 2 + 20 * 5 - 100 \div 10 = N$
- B)  $((2 * N + 20) * 5 - 100) \div 10 = N$
- C)  $(N + N + 20) * 5 - 100 \div 10 = N$
- D)  $((N \div 10) - 100) * 5 + 20) * 2 = N$

53) Use the problem below to answer the question that follows:

T shirts are on sale for 20% off. Tasha paid \$8.73 for a shirt; what is the regular price of the shirt? There is no tax on clothing purchases under \$175.

Let  $p$  represent the regular price of these t-shirt. Which of the following equations is correct?

- A)  $0.8p = \$8.73$
- B)  $\$8.73 + 0.2 * \$8.73 = p$
- C)  $1.2 * \$8.73 = p$
- D)  $p - 0.2 * \$8.73 = p$

54) Taxicab fares in Boston (spring 2011) are \$2.60 for the first  $\frac{1}{7}$  of a mile or less and \$0.40 for each  $\frac{1}{7}$  of a mile after that.

Let  $d$  represent the distance the passenger travels in miles (with  $d > \frac{1}{7}$  mile). Which of the following expressions represents the total fare?

- A)  $\$2.60 + \$0.40d$
- B)  $\$2.60 + \$0.40\frac{d}{7}$
- C)  $\$2.60 + \$0.40(7d - 1)$
- D)  $\$2.60 + \$0.40\left(7d - \frac{1}{7}\right)$

55) Cell phone plan A charges \$3 per month plus \$0.10 per minute. Cell phone plan B charges \$29.99 per month, with no fee for the first 400 minutes and then \$0.20 for each additional minute. Which equation can be used to solve for the number of minutes,  $m$  (with  $m > 400$ ) that a person would have to spend on the phone each month in order for the bills for plan A and plan B to be equal?

- A)  $3.10m = 400 + 0.2m$
- B)  $3 + 0.1m = 29.99 + .20m$
- C)  $3 + 0.1m = 400 + 29.99 + .20(m - 400)$
- D)  $3 + 0.1m = 29.99 + .20(m - 400)$

56) A sales company pays the representatives \$2 for each item sold, plus 40% of the price of the item. The rest of the money that the representatives collect goes to the company. All transactions are in cash, and all items cost \$4 or more. If the price of an item in dollars is  $p$ , which expression represents the amount of money the company collects when the item is sold?

A)  $\frac{3}{5}p - 2$

B)  $\frac{3}{5}(p - 2)$

C)  $\frac{2}{5}p + 2$

D)  $\frac{2}{5}p - 2$

57) Here is a student's work in solving  $3x - 4 = -2x + 6$ :

$$3x - 4 = -2x + 6$$

$$3x - 4 + 4 = -2x + 6 + 4$$

$$3x = -2x + 10$$

$$3x - 2x = 10$$

$$x = 10$$

Which of the following statements is true?

- A) The student's solution is correct.
- B) The student did not correctly use properties of integers.
- C) The student did not correctly use the distributive property.
- D) The student did not correctly use the commutative property.

58) Solve for  $x$ :  $4 - \frac{2}{3}x = 2x$

A)  $x = 3$

B)  $x = -3$

C)  $x = \frac{3}{2}$

D)  $x = -\frac{3}{2}$

**0021 Understand the concept of function**

59) In which table below is  $y$  a function of  $x$ ?

A)

$x$	$y$
3	1
4	2
6	3
3	4
4	5

B)

$x$	$y$
3	4
4	3
6	5
3	5
4	3

C)

$x$	$y$
1	1
1	2
1	3
1	4
1	5

D)

$x$	$y$
3	1
4	2
6	3
3	1
4	2

60) Which of the graphs below represent functions?

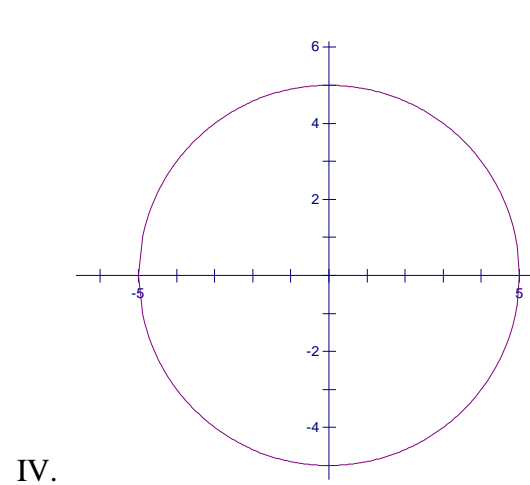
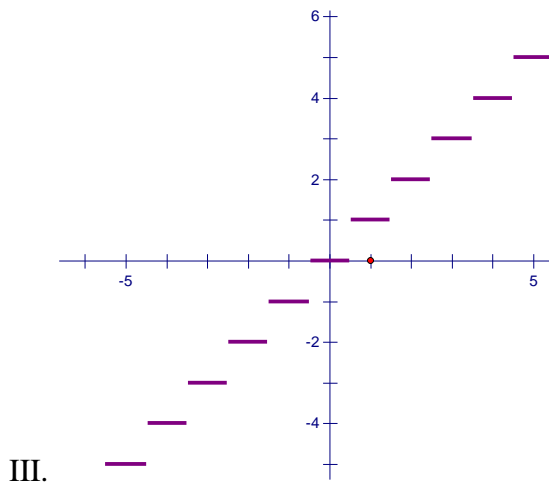
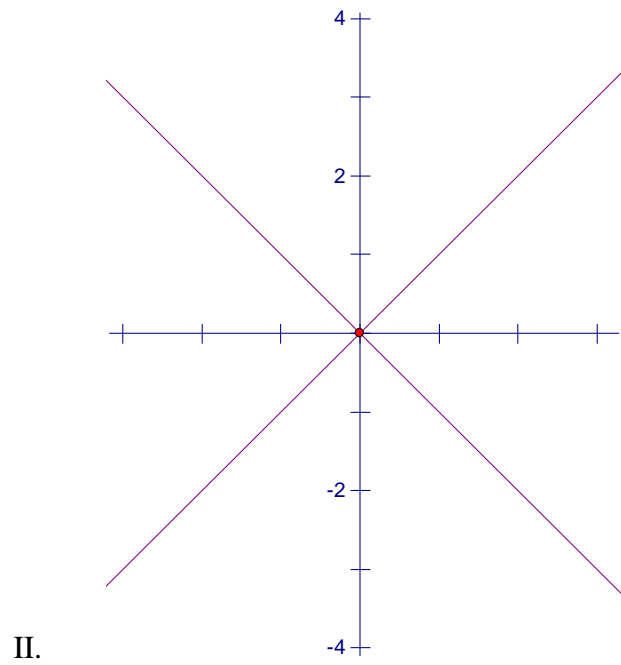
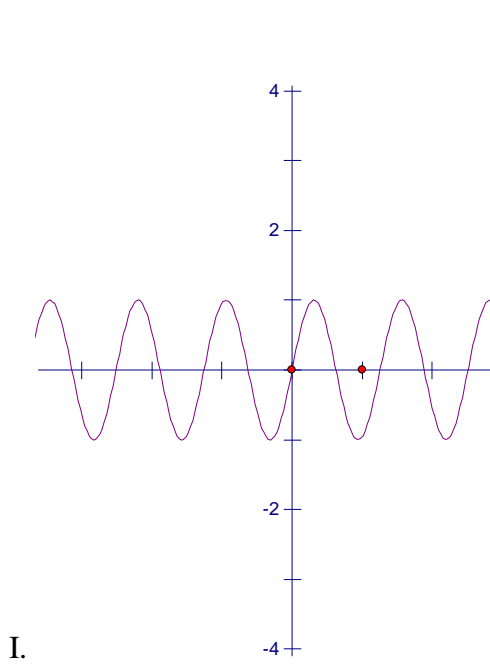

- A) I only
- B) I and III only
- C) II and III only
- D) I, II, and IV only

61) Below are four inputs and outputs for a function machine representing the function  $A$ :

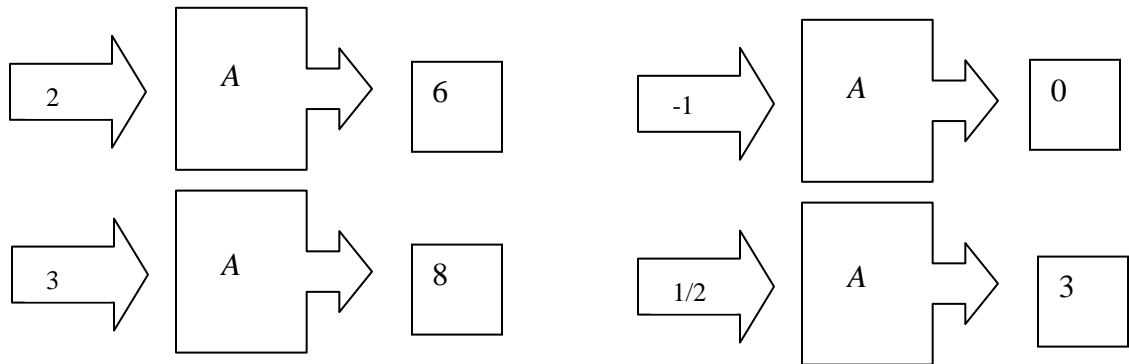

Which of the following equations could also represent  $A$  for the values shown?

- A)  $A(n) = n + 4$
- B)  $A(n) = n + 2$
- C)  $A(n) = 2n + 2$
- D)  $A(n) = 2(n + 2)$

62) The mapping diagrams below represent several people ( D,E,F,G,H, and I ) and their choices of dinner (B=Beef, C=Chicken or V=Vegetarian).

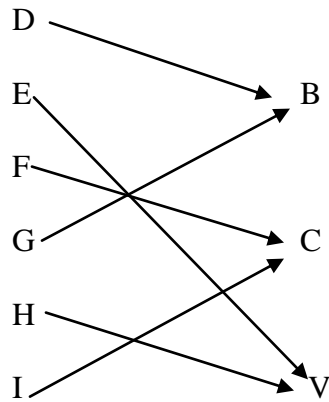

**Diagram I**

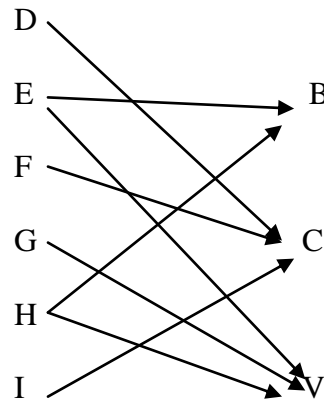
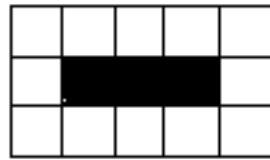
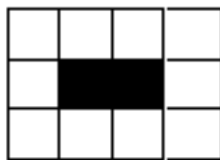
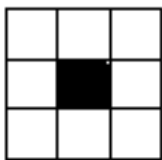

**Diagram II**

Which, if any, of the above are functions?

- A) Diagram I only
- B) Diagram II only
- C) Neither diagram
- D) Both diagrams

63) The pattern below consists of a row of black squares surrounded by white squares.



How many white squares would surround a row of 157 black squares?

- A) 314
- B) 317
- C) 318
- D) 320

64) The “houses” below are made of toothpicks and gum drops.

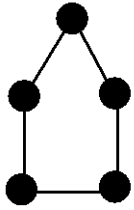

1 House  
5 Toothpicks  
5 Gum Drops

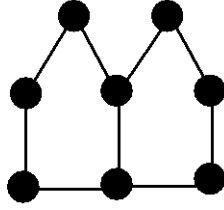

2 Houses  
9 Toothpicks  
8 Gum Drops

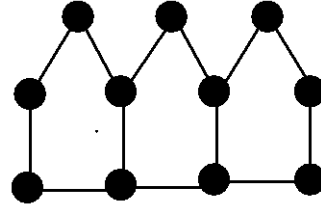

3 Houses  
13 Toothpicks  
11 Gum Drops

How many toothpicks are there in a row of 53 houses?

- A) 212
- B) 213
- C) 217
- D) 265

65) Using the diagram in question 64, which of the following does not represent the number of gumdrops in a row of  $h$  houses?

- A)  $2 + 3h$
- B)  $5 + 3(h - 1)$
- C)  $5 + 3h$
- D)  $h + (h + 1) + (h + 1)$

66)

<b>y</b>	<b>5</b>	-5	-3	-1	1	3	5
<b>4</b>		-4	-2	0	2	4	6
<b>3</b>		-3	-1	1	3	5	7
<b>2</b>		-2	0	2	4	6	8
<b>1</b>		-1	1	3	5	7	9
<b>0</b>		0	2	4	6	8	10
		<b>0</b>	<b>1</b>	<b>2</b>	<b>3</b>	<b>4</b>	<b>5</b>

**x**

Each number in the table above represents a value  $W$  that is determined by the values of  $x$  and  $y$ . For example, when  $x = 3$  and  $y = 1$ ,  $W = 5$ . What is the value of  $W$  when  $x = 9$  and  $y = 14$ ?

- A) -4
- B) 4
- C) 19
- D) 37

67)

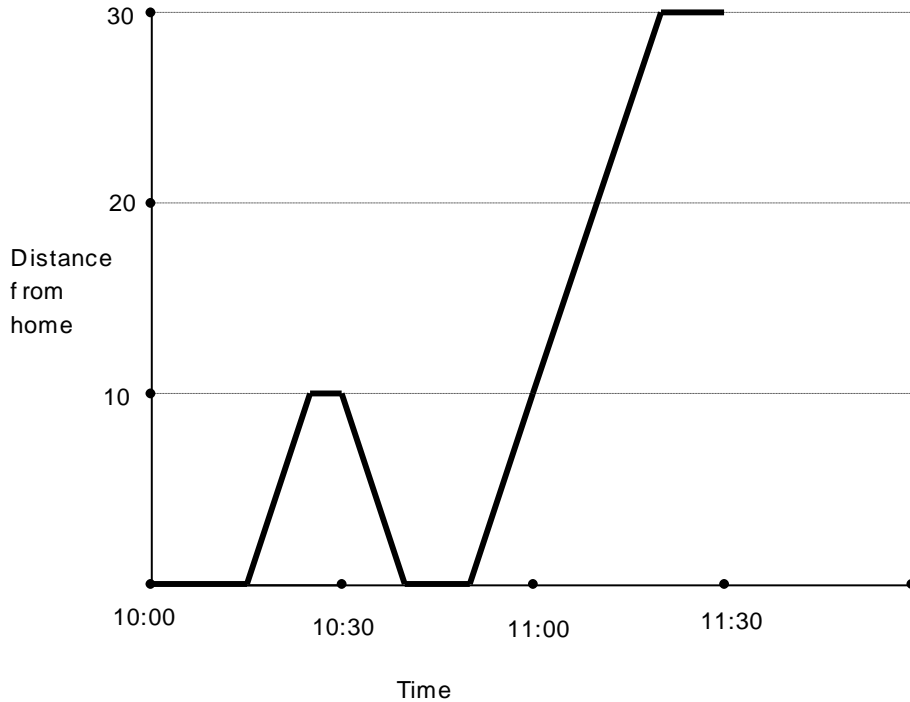

The graph above best matches which of the following scenarios:

- A) George left home at 10:00 and drove to work on a crooked path. He was stopped in traffic at 10:30 and 10:45. He drove 30 miles total.
- B) George drove to work. On the way to work there is a little hill and a big hill. He slowed down for them. He made it to work at 11:15.
- C) George left home at 10:15. He drove 10 miles, then realized he'd forgotten something at home. He turned back and got what he'd forgotten. Then he drove in a straight line, at many different speeds, until he got to work around 11:15.
- D) George left home at 10:15. He drove 10 miles, then realized he'd forgotten something at home. He turned back and got what he'd forgotten. Then he drove at a constant speed until he got to work around 11:15.

68) The function  $d(x)$  gives the result when 12 is divided by  $x$ . Which of the following is a graph of  $d(x)$ ?

A)

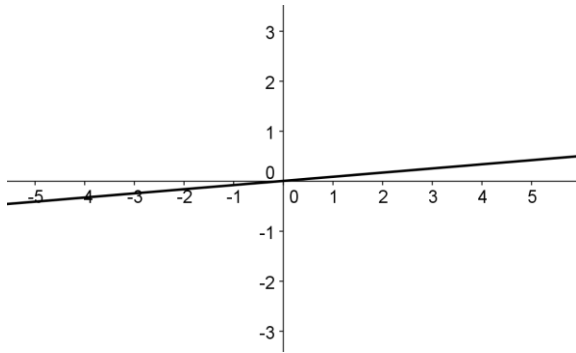

B)

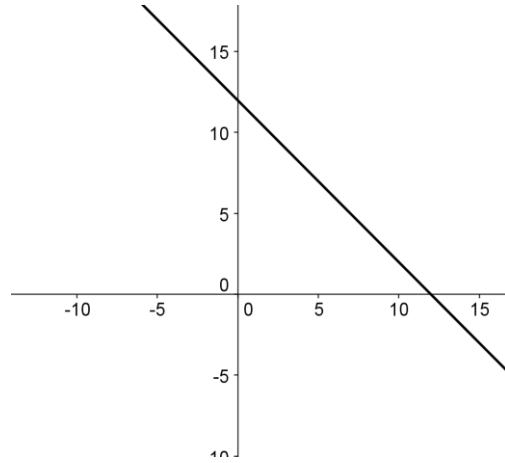

C)

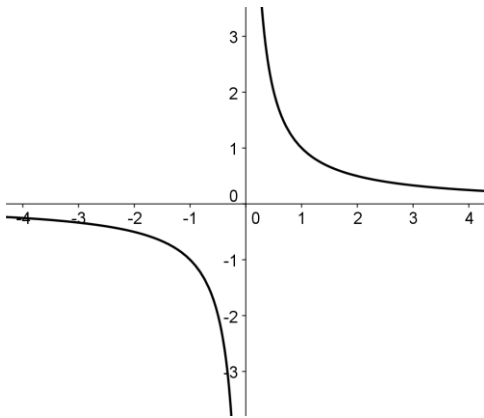

D)

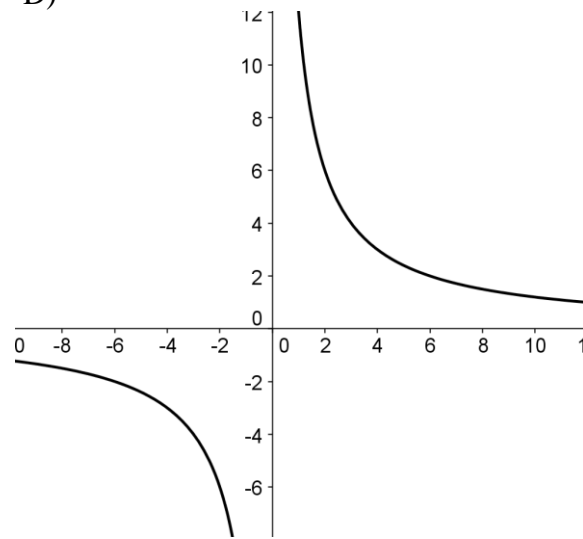

**0022 Understand linear functions and linear equations.**

69) There are 15 students for every teacher. Let  $t$  represent the number of teachers and let  $s$  represent the number of students. Which of the following equations is correct?

A)  $t = s + 15$

B)  $s = t + 15$

C)  $t = 15s$

D)  $s = 15t$

70)

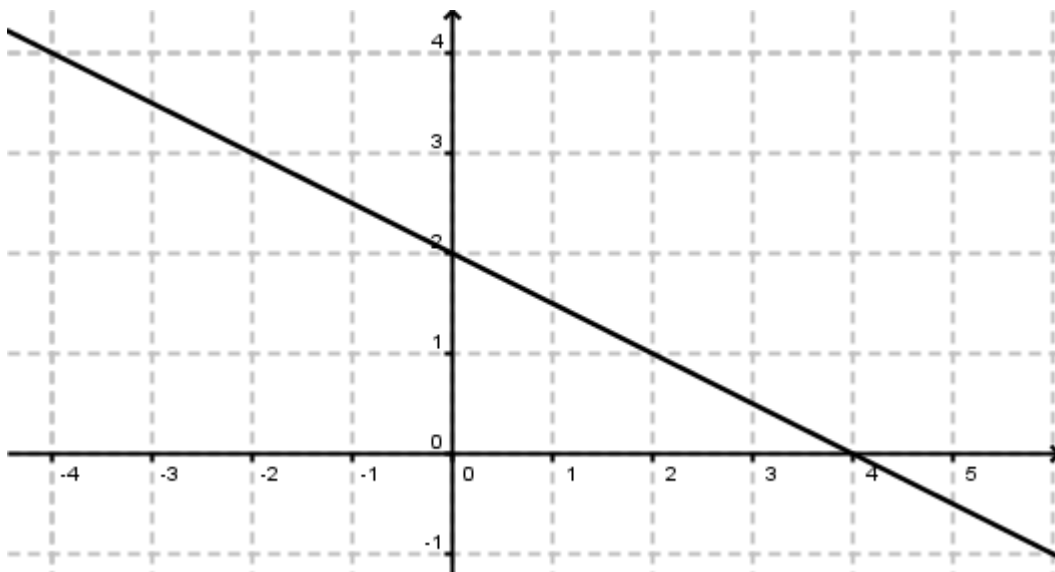

Which of the following is a correct equation for the graph of the line depicted above? Assume that the horizontal axis represents  $x$  and the vertical  $y$ .

A)  $y = -\frac{1}{2}x + 2$

B)  $4x = 2y$

C)  $y = x + 2$

D)  $y = 2x + 2$

71) A map has a scale of 3 inches = 100 miles. Cities A and B are 753 miles apart. Let  $d$  be the distance between the two cities on the map. Which of the following is not correct?

A)  $\frac{3}{100} = \frac{d}{753}$

B)  $\frac{3}{100} = \frac{753}{d}$

C)  $\frac{3}{d} = \frac{100}{753}$

D)  $100d = 3 \cdot 753$

72) Which of the following is the equation of a linear function?

A)  $y = x^2 + 2x + 7$

B)  $y = 2^x$

C)  $y = \frac{15}{x}$

D)  $y = x + (x + 4)$

73) The American's with Disabilities Act (ADA) regulations state that the maximum slope for a wheelchair ramp in new construction is 1:12, although slopes between 1:16 and 1:20 are preferred. The maximum rise for any run is 30 inches. The graph below shows the rise and runs of four different wheelchair ramps. Which ramp is in compliance with the ADA regulations for new construction?

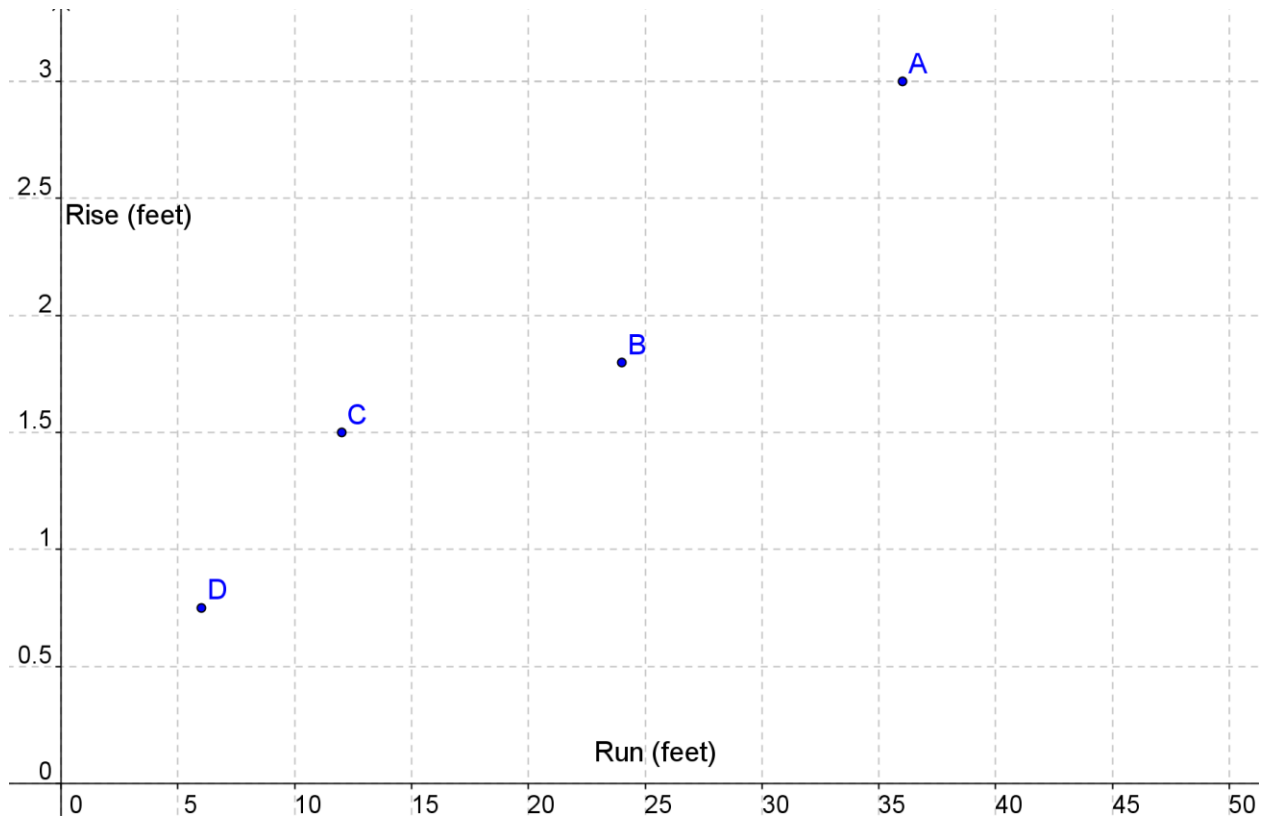

74) A publisher prints a series of books with covers made of identical material and use the same thickness of paper for each page. The covers of the book together measure 0.4 cm, and 125 pieces of the paper used together measures 1 cm.

The publisher uses a linear function to determine the total thickness,  $T(n)$ , of a book made with  $n$  sheets of paper. What are the slope and intercept of  $T(n)$ ?

A) Intercept = 0.4 cm, Slope = 125 cm/page

B) Intercept = 0.4 cm, Slope =  $\frac{1}{125}$  cm/page

C) Intercept = 125 cm, Slope = 0.4 cm

D) Intercept =  $\frac{1}{125}$  cm, Slope = 0.4 pages/cm

74) A family went on a long car trip. Below is a graph of how far they had driven at each hour.

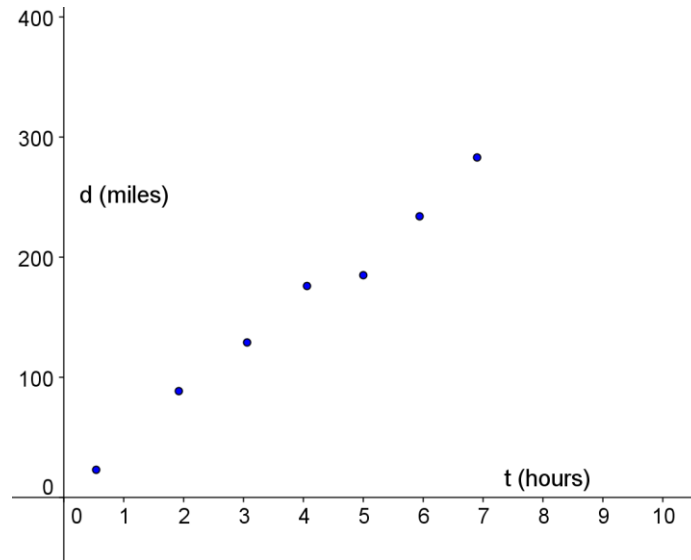

Which of the following is closest to their average speed driving on the trip?

- A) 20 miles per hour
- B) 30 miles per hour
- C) 40 miles per hour
- D) 50 miles per hour

75) In June of 2011, 1 dollar was worth the same as 0.698 Euros, and 1 dollar was also worth the same as 80.11 Japanese Yen. Which of the expressions below gives the number of Yen that are worth 1 Euro?

- A)  $80.11 \cdot 0.698$
- B)  $\frac{0.698}{80.11}$
- C)  $\frac{80.11}{0.698}$
- D)  $\frac{1}{0.698} \cdot \frac{1}{80.11}$

76) Which of the following is a graph of  $y = 2x - 5$ ? (continued on the next page)

A)

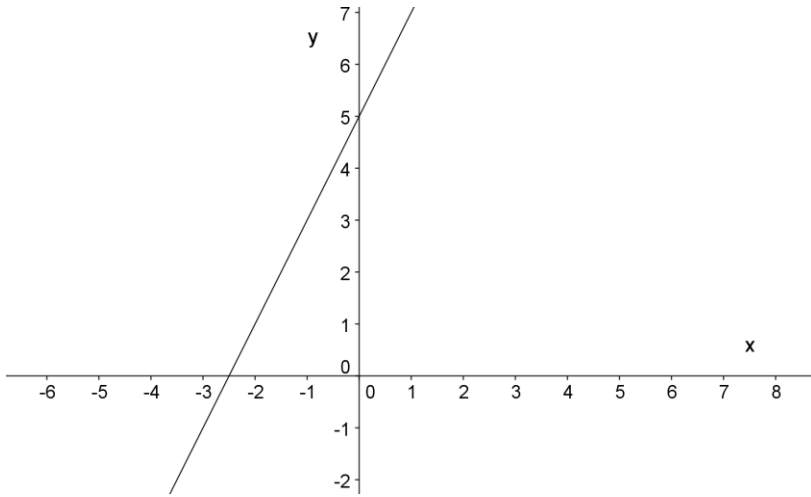

B)

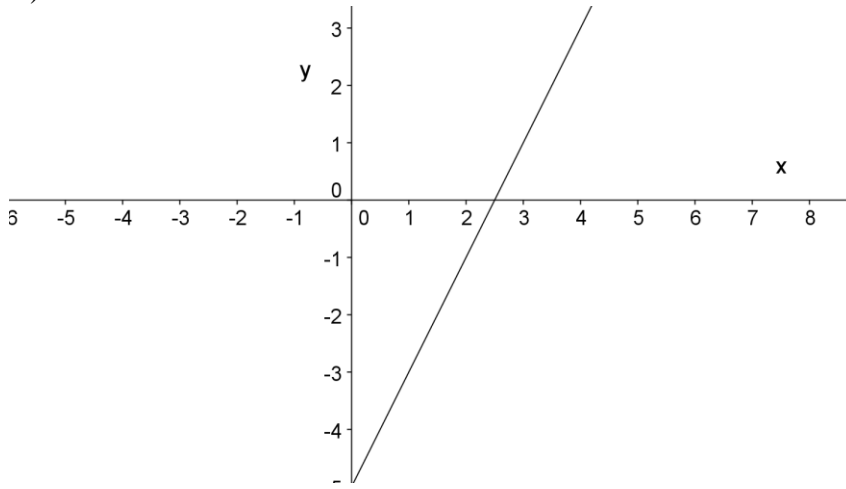

C)

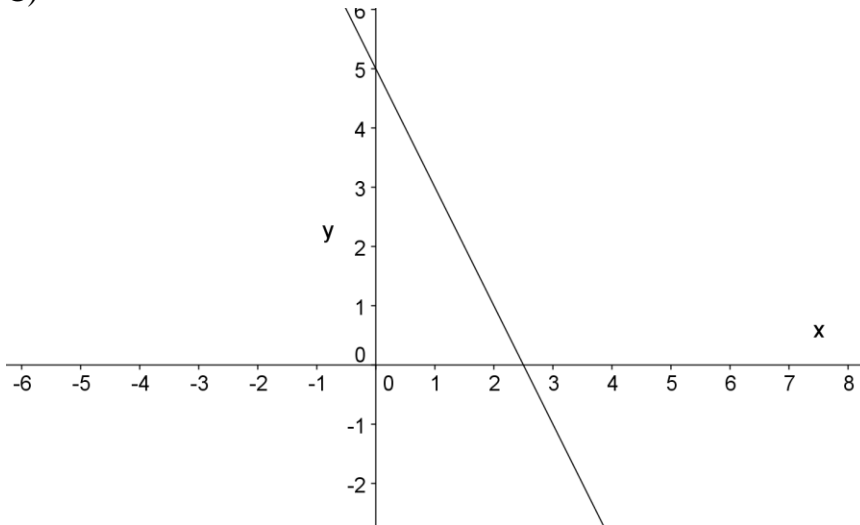

D)

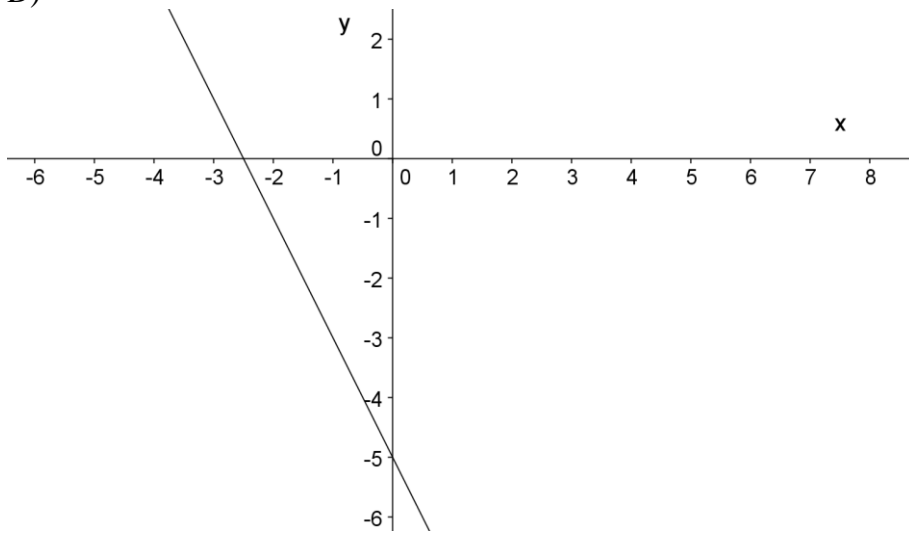

**Subarea III: Geometry and Measurement (18%)**

**0023 Understand and apply concepts of measurement**

77) The picture below represents a board with pegs on it, where the closest distance between two pegs is 1 cm. What is the area of the pentagon shown?

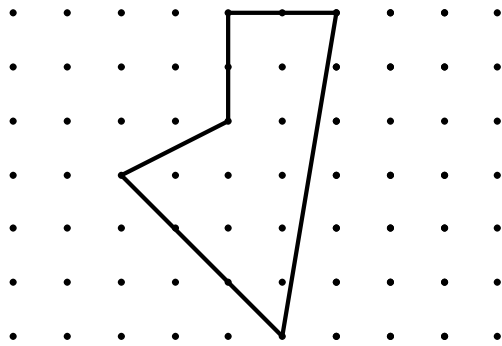

A)  $8 \text{ cm}^2$

B)  $11 \text{ cm}^2$

C)  $11.5 \text{ cm}^2$

D)  $12.5 \text{ cm}^2$

78) The triangle below is on a geoboard where the closest distance between two pegs is 2 cm. What is the area of the triangle?

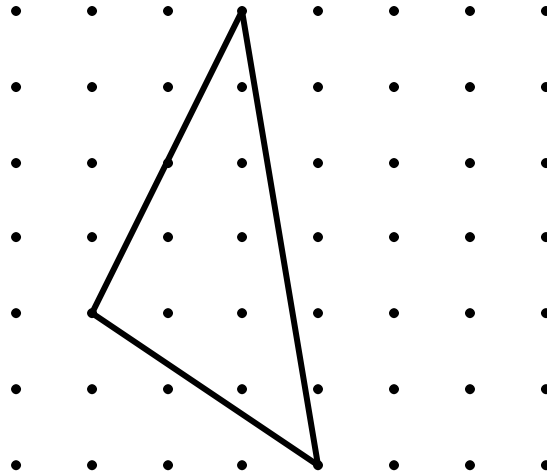

- A)  $7 \text{ cm}^2$
- B)  $8 \text{ cm}^2$
- C)  $16 \text{ cm}^2$
- D)  $32 \text{ cm}^2$

79) The rectangular solid depicted below has volume  $384 \text{ in}^3$ . What are the dimensions of each of the individual cubes that make up the solid?

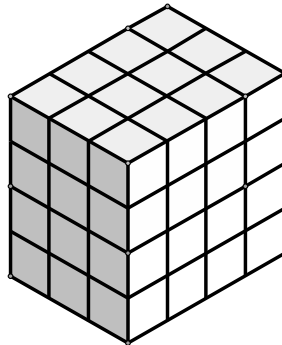

- A) 2 in x 2 in x 2 in
- B) 4 in x 4 in x 4 in
- C) 8 in x 8 in x 8 in
- D) 48 in x 48 in x 48 in

80) Each individual cube that makes up the rectangular solid depicted below has 6 inch sides. What is the surface area of the solid in square feet?

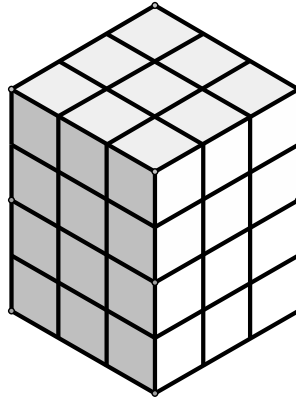

- A)  $11 \text{ ft}^2$
- B)  $16.5 \text{ ft}^2$
- C)  $33 \text{ ft}^2$
- D)  $66 \text{ ft}^2$

81) What is the area of an equilateral triangle with side length  $x$ ?

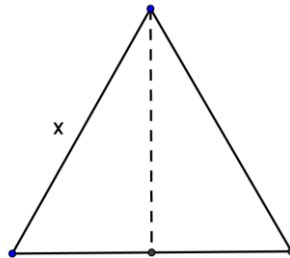

- A)  $\frac{x^2}{2}$
- B)  $\frac{x^2\sqrt{3}}{4}$
- C)  $\frac{x^2\sqrt{3}}{2}$
- D)  $x^2\sqrt{3}$

82) What is the length of side  $\overline{BD}$  in the triangle below, where  $\angle DBA$  is a right angle?

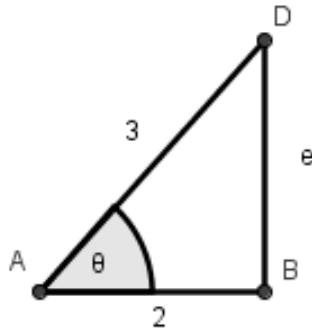

- A) 1
- B)  $\sqrt{5}$
- C)  $\sqrt{13}$
- D) 5

83) An above-ground swimming pool is in the shape of a regular hexagonal prism is one meter high and holds 65 cubic meters of water. A second pool has a base that is also a regular hexagon, but with sides twice as long as the sides in the first pool. This second pool is also one meter high. How much water will the second pool hold?

- A)  $65 \text{ m}^3$
- B)  $(65 \times 2) \text{ m}^3$
- C)  $(65 \times 4) \text{ m}^3$
- D)  $(65 \times 8) \text{ m}^3$

84) The column below consists of two cubes and a cylinder. The cylinder has diameter  $y$ , which is also the length of the sides of each cube. The total height of the column is  $5y$ . Which of the formulas below gives the surface area of the column?



A)  $12y^2 + \frac{5}{2}\pi y^2$

B)  $12y^2 + \frac{7}{2}\pi y^2$

C)  $10y^2 + 3\pi y^2$

D)  $10y^2 + 5\pi y^2$

85) What is the volume of the column depicted in problem 84?

A)  $2y^3 + \frac{3\pi y^3}{4}$

B)  $2y^3 + 3\pi y^3$

C)  $y^3 + 5\pi y^3$

D)  $2y^3 + \frac{3\pi y^3}{8}$

86) A car is traveling at 60 miles per hour. Which of the expressions below could be used to compute how many feet the car travels in 1 second? Note that 1 mile = 5,280 feet.

- A)  $60 \frac{\text{miles}}{\text{hour}} \cdot 5280 \frac{\text{feet}}{\text{mile}} \cdot 60 \frac{\text{minutes}}{\text{hour}} \cdot 60 \frac{\text{seconds}}{\text{minute}}$
- B)  $60 \frac{\text{miles}}{\text{hour}} \cdot 5280 \frac{\text{feet}}{\text{mile}} \cdot \frac{1 \text{ hour}}{60 \text{ minutes}} \cdot \frac{1 \text{ minute}}{60 \text{ seconds}}$
- C)  $60 \frac{\text{miles}}{\text{hour}} \cdot \frac{1 \text{ foot}}{5280 \text{ miles}} \cdot 60 \frac{\text{hours}}{\text{minute}} \cdot \frac{1 \text{ minute}}{60 \text{ seconds}}$
- D)  $60 \frac{\text{miles}}{\text{hour}} \cdot \frac{1 \text{ mile}}{5280 \text{ feet}} \cdot 60 \frac{\text{minutes}}{\text{hour}} \cdot \frac{1 \text{ minute}}{60 \text{ seconds}}$

87) The speed of sound in dry air at 68 degrees F is 343.2 meters per second. Which of the expressions below could be used to compute the number of kilometers that a sound wave travels in 10 minutes (in dry air at 68 degrees F)?

- A)  $343.2 \times 60 \times 10$
- B)  $343.2 \times 60 \times 10 \times \frac{1}{1000}$
- C)  $343.2 \times \frac{1}{60} \times 10$
- D)  $343.2 \times \frac{1}{60} \times 10 \times \frac{1}{1000}$

88) A homeowner is planning to tile the kitchen floor with tiles that measure 6 inches by 8 inches. The kitchen floor is a rectangle that measures 10 ft by 12 ft, and there are no gaps between the tiles. How many tiles does the homeowner need?

- A) 30
- B) 120
- C) 300
- D) 360

89) A family on vacation drove the first 200 miles in 4 hours and the second 200 miles in 5 hours. Which expression below gives their average speed for the entire trip?

A)  $\frac{400}{9}$

B)  $\left(\frac{200}{4} + \frac{200}{5}\right) \div 2$

C)  $\left(\frac{200}{4} + \frac{200}{5}\right)$

D)  $\left(\frac{400}{4} + \frac{400}{5}\right)$

90) A cylindrical soup can has diameter 7 cm and height 11 cm. The can holds  $g$  grams of soup. How many grams of the same soup could a cylindrical can with diameter 14 cm and height 33 cm hold?

A)  $6g$

B)  $12g$

C)  $18g$

D)  $36g$

91) Which of the following is closest to the height of a college student in centimeters?

A) 1.6 cm

B) 16 cm

C) 160 cm

D) 1600 cm

92) Which of the following is closest to the distance from New York to California in kilometers?

- A) 50 km
- B) 500 km
- C) 5000 km
- D) 50,000 km

93) The temperature in Massachusetts is 30 degrees Celsius. What season is it most likely to be?

- A) Summer
- B) Fall
- C) Winter
- D) Spring

94) The normal body temperature for a dog falls in the range of 100.5 to 102.5 Fahrenheit. What is this normal range in Celsius?

- A) 97.1 to 99.1 degrees Celsius
- B) 76.3 to 78.1 degrees Celsius
- C) 52.0 to 53.8 degrees Celsius
- D) 38.1 to 39.2 degrees Celsius

**0024 Understand and apply concepts of geometry.**

95) What is the perimeter of a right triangle with legs of length  $x$  and  $2x$ ?

- A)  $6x$
- B)  $3x + 5x^2$
- C)  $3x + \sqrt{5}x^2$
- D)  $3x + \sqrt{5}x$

96) The polygon depicted below is drawn on dot paper, with the dots spaced 1 inch apart. What is the perimeter of the polygon?

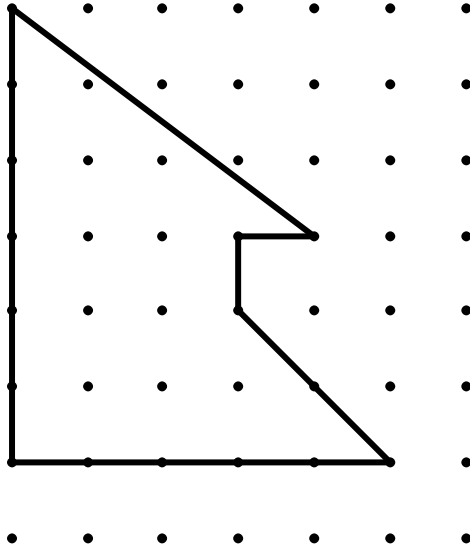

- A)  $16 + \sqrt{2}$
- B)  $16 + 2\sqrt{2}$
- C) 16
- D) 18

97) What is the mathematical name of the three-dimensional polyhedron depicted below?



- A) Tetrahedron
- B) Triangular Prism
- C) Triangular Pyramid
- D) Trigon

98) Which of the following is not possible?

- A) An equiangular triangle that is not equilateral.
- B) An equiangular quadrilateral that is not equilateral.
- C) An equilateral quadrilateral that is not equiangular
- D) An equiangular hexagon that is not equilateral.

99) How many lines of reflective symmetry and how many centers of rotational symmetry does the parallelogram depicted below have?

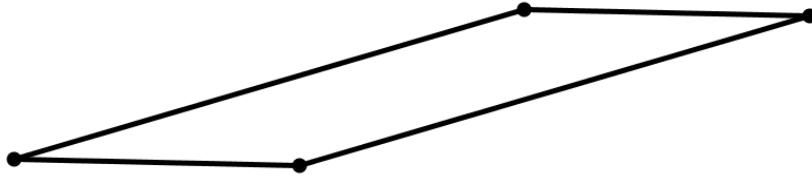

- A) 4 lines of reflective symmetry, 1 center of rotational symmetry
- B) 2 lines of reflective symmetry, 1 center of rotational symmetry
- C) 0 lines of reflective symmetry, 1 center of rotational symmetry
- D) 2 lines of reflective symmetry, 0 centers of rotational symmetry

100) Which of the following nets will not fold into a cube?

A)

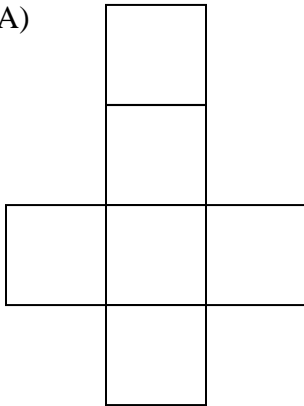

B)

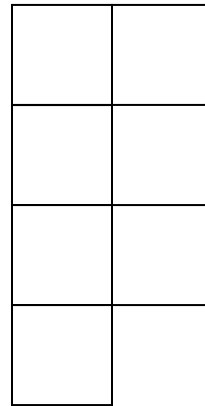

C)

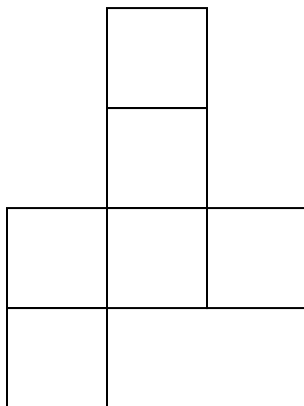

D)

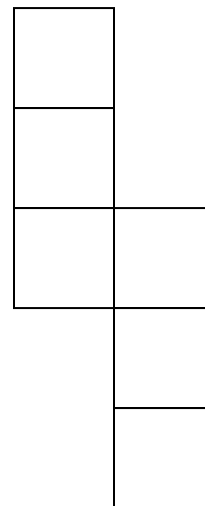

101) Which of the following sets of polygons can be assembled to form a pentagonal pyramid?

- A) 2 pentagons and 5 rectangles
- B) 1 square and 5 equilateral triangles
- C) 1 pentagon and 5 isosceles triangles
- D) 1 pentagon and 10 isosceles triangles

102) Which property is not shared by all rhombi?

- A) 4 congruent sides
- B) A center of rotational symmetry
- C) 4 congruent angles
- D) 2 sets of parallel sides

103) Below are front, side, and top views of a three-dimensional solid.

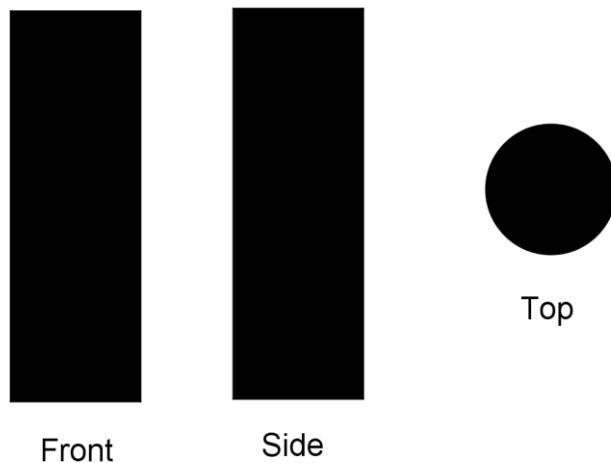

Which of the following could be the solid shown above?

- A) A sphere
- B) A cylinder
- C) A cone
- D) A pyramid

104) Below are front, side, and top views of a three-dimensional solid.

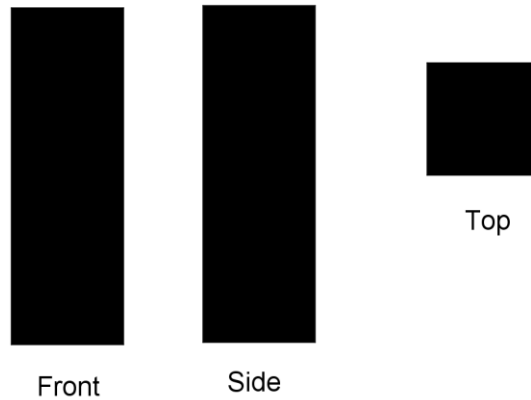

Which of the following could be the solid shown above?

- A) A rectangular prism
- B) A cube
- C) A rectangle
- D) A trapezoid

105) Use the graph below to answer the question that follows.

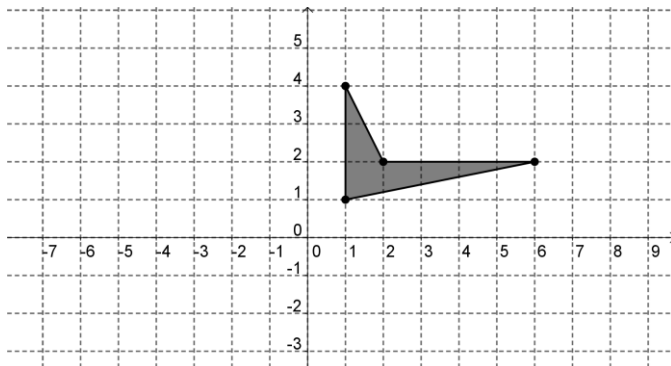

If the polygon shown above is rotated 90 degrees counter-clockwise about the origin, which of the following graphs is the result? (see next page)

A)

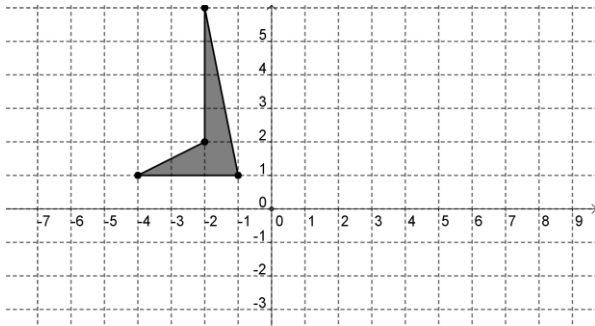

B)

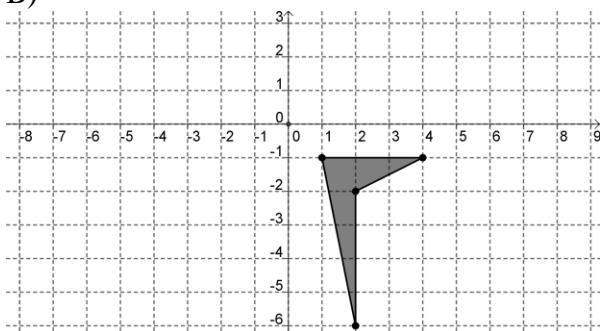

C)

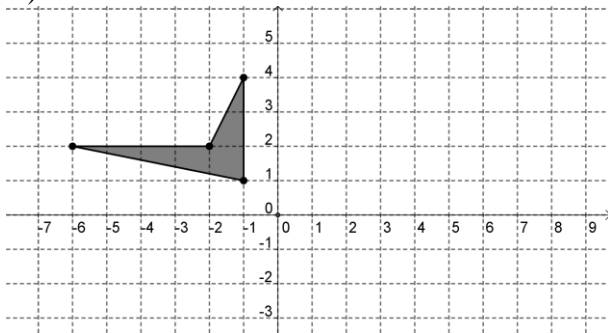

D)

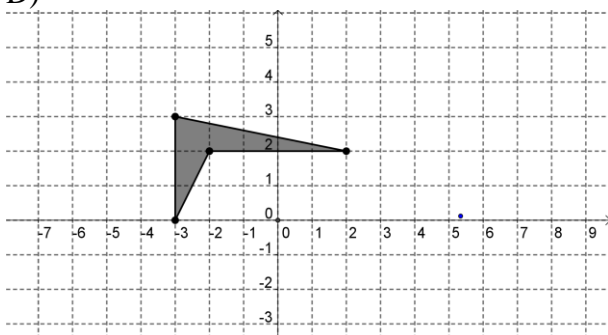

106) Use the graph below to answer the question that follows.

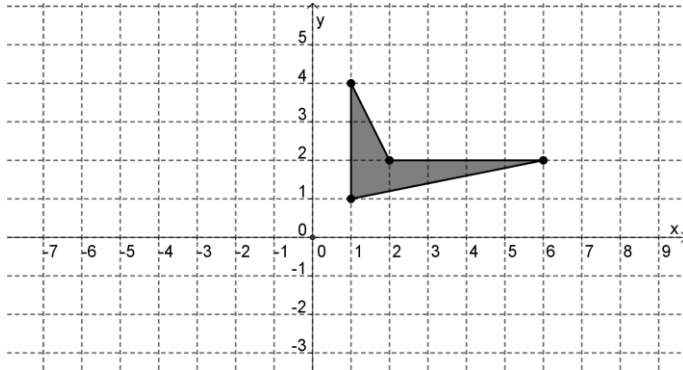

If the polygon shown above is reflected about the y axis and then rotated 90 degrees clockwise about the origin, which of the following graphs is the result? (continues onto next page)

A)

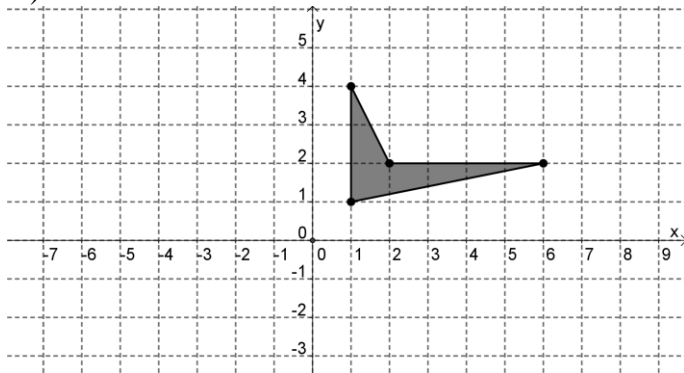

B)

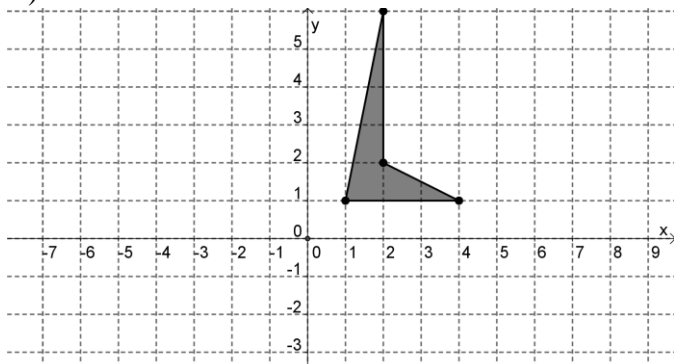

C)

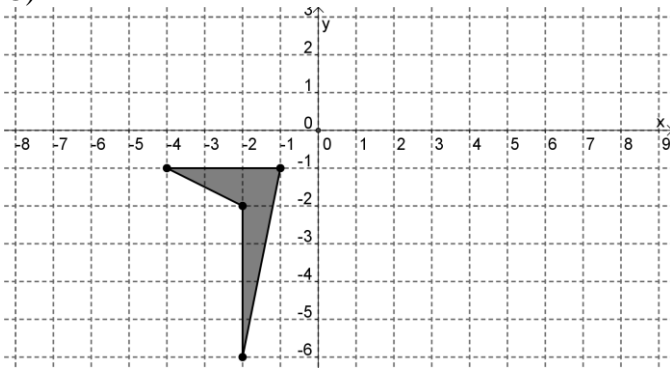

D)

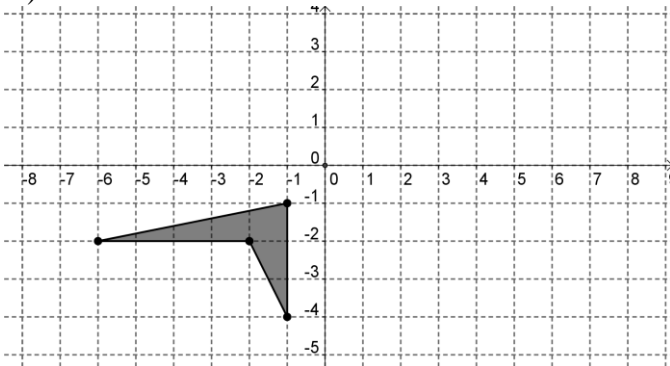

107) What set of transformations will transform the leftmost image into the rightmost image?

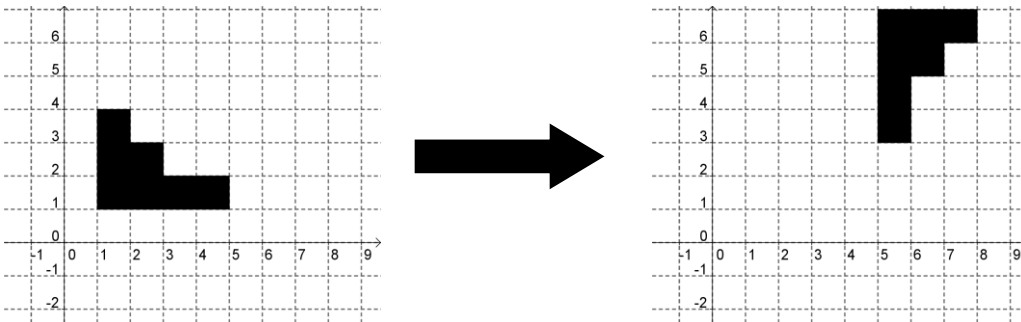

- A) A 90 degree clockwise rotation about (2,1) followed by a translation of two units to the right.
- B) A translation 3 units up, followed by a reflection about the line  $y = x$ .
- C) A 90 degree clockwise rotation about (5,1), followed by a translation of two units up.
- D) A 90 degree counterclockwise rotation about (3,3) followed by a translation of two units up.

108) What is the dilation factor in the dilation about the origin that transforms the leftmost image into the rightmost image?

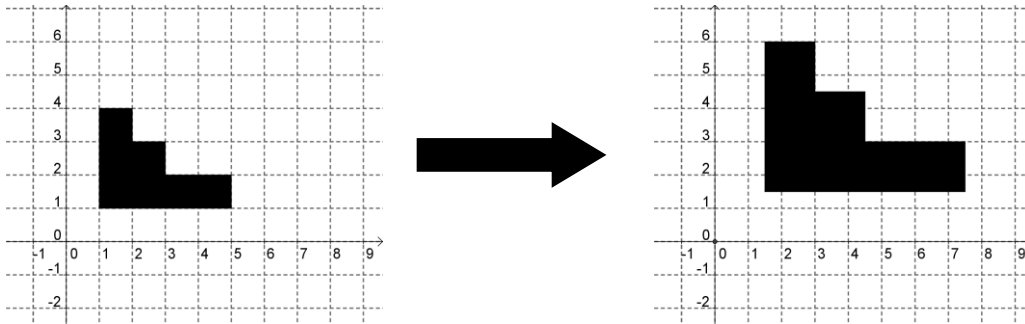

- A) 0.5
- B) 1
- C) 1.5
- D) 2

#### IV STATISTICS AND PROBABILITY [9%]

##### 0025 Understand descriptive statistics.

109) A teacher has a list of all the countries in the world and their populations in January 2011. She is going to have her students use technology to compute the mean and median of the numbers on the list.

Which of the following statements is true?

- A) The teacher can be sure that the mean and median will be the same without doing any computation.
- B) The teacher can be sure that the mean is bigger than the median without doing any computation.
- C) The teacher can be sure that the median is bigger than the mean without doing any computation.
- D) There is no way for the teacher to know the relative size of the mean and median without computing them.

110) The histogram below shows the number of pairs of footwear owned by a group of college students.

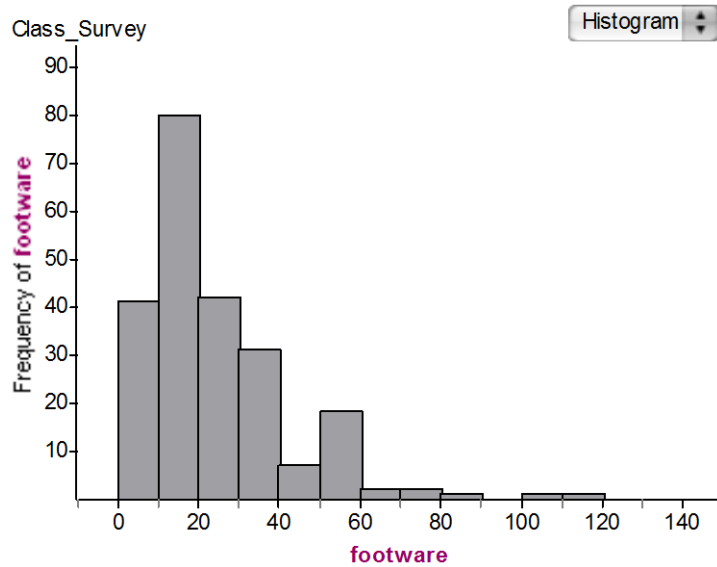

Which of the following statements can be inferred from the graph above?

- A) The median number of pairs of footwear owned is between 50 and 60 pairs.
- B) The mode of the number of pairs of footwear owned is 20.
- C) The mean number of pairs of footwear owned is less than the median number of pairs of footwear owned.
- D) The median number of pairs of footwear owned is between 10 and 20.

112) The chart below gives percentiles for the number of sit-ups that boys of various ages can do in 60 seconds (source <http://www.exrx.net/Testing/YouthNorms.html> , on June 24, 2011)

### Sit-ups (Boys)

	Age												
Percentile	5	6	7	8	9	10	11	12	13	14	15	16	17
95	30	36	42	48	47	50	51	56	58	59	59	61	62
75	23	26	33	37	38	40	41	46	48	49	49	51	52
50	18	20	26	30	32	34	37	39	41	42	44	45	46
25	11	15	19	25	25	27	30	31	35	36	38	38	38
5	2	6	10	15	15	15	17	19	25	27	28	28	25
Repetitions													

Which of the following statements can be inferred from the above chart?

- A) 95% of 12 year old boys can do 56 sit-ups in 60 seconds.
- B) At least 75% of 16 year old boys can only do 51 or fewer sit-ups in 60 seconds.
- C) At most 25% of 7 year old boys can do 19 or more sit-ups in 60 seconds.
- D) Half of all 13 year old boys can do less than 41 sit-ups in 60 seconds and half can do more than 41 sit-ups in 60 seconds.

113) The histogram below shows the frequency of a class's scores on a 4 question quiz.

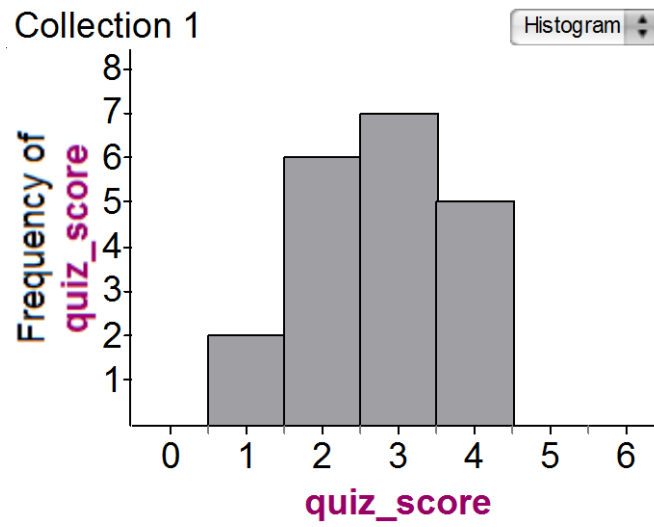

What was the mean score on the quiz?

- A) 2.75
- B) 2
- C) 3
- D) 2.5

114) Robin is saving for a new phone. At the end of each week, she counted her money. She only saved bills of denomination \$5 or above, so her total was always a multiple of 5. Below is a line plot of her total savings for the first seven weeks:

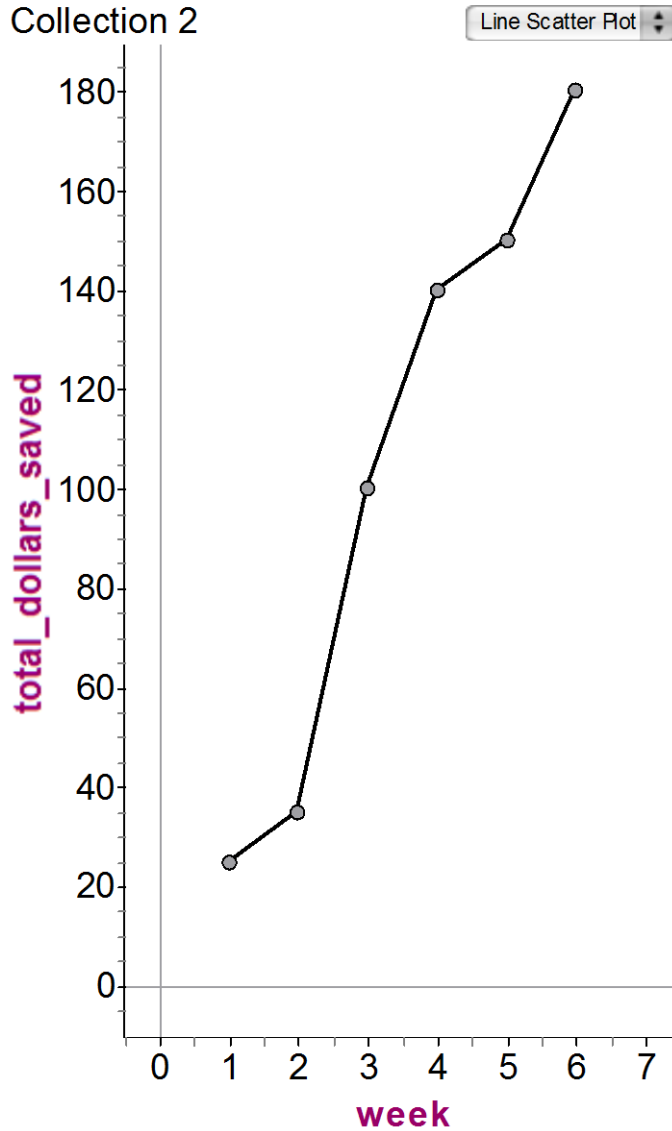

What was the total gain in Robin's savings when she counted her money at the end of week 3?

- A) \$25
- B) \$35
- C) \$65
- D) \$100

115) The Venn Diagram below gives data on the number of seniors, athletes, and vegetarians in the student body at a college:

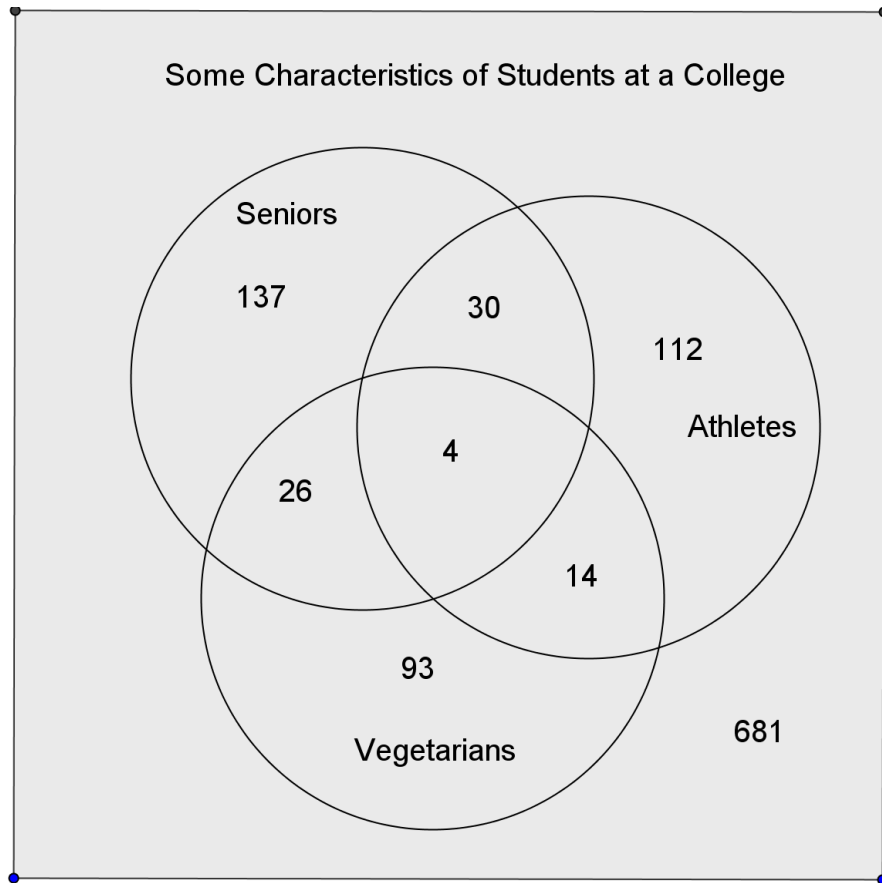

How many students at the college are seniors who are not vegetarians?

- A) 137
- B) 167
- C) 197
- D) 279

116) The histogram on the left shows the average life expectancies for women in different countries in Africa in 1998; the histogram on the right gives similar data for Europe:

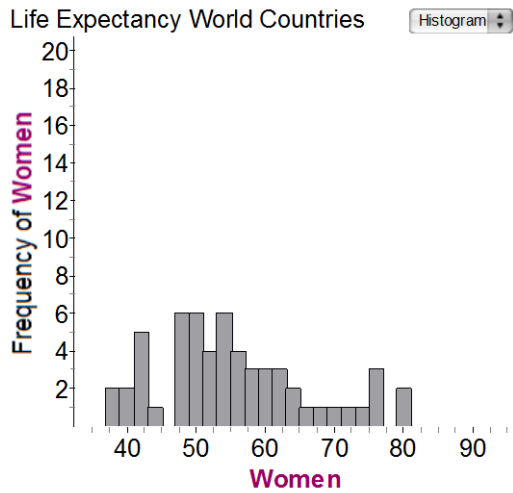

Region = "Africa"

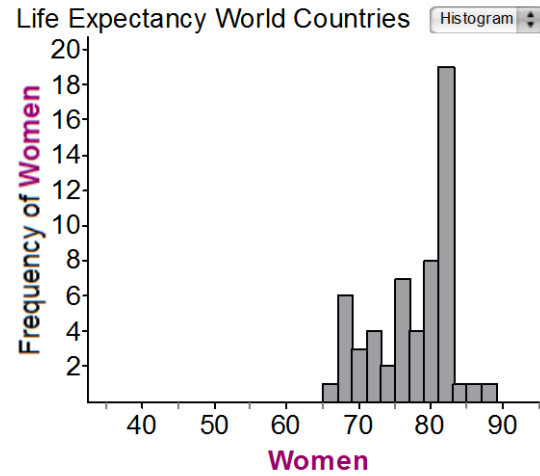

Region = "Europe"

How much bigger is the range of the data for Africa than the range of the data for Europe?

- A) 10 years
- B) 12 years
- C) 20 years
- D) 35 years

**0026 Understand and apply basic concepts of probability**

117) What is the probability that two randomly selected people were born on the same day of the week? Assume that all days are equally probable.

- A)  $\frac{1}{7}$
- B)  $\frac{1}{14}$
- C)  $\frac{1}{42}$
- D)  $\frac{1}{49}$

118) There are six gumballs in a bag – two red and four green. Six children take turns picking a gumball out of the bag without looking. They do not return any gumballs to the bag. What is the probability that the first two children to pick from the bag pick the red gumballs?

A)  $\frac{1}{6}$

B)  $\frac{1}{8}$

C)  $\frac{1}{9}$

D)  $\frac{1}{15}$

119) The table below gives data from various years on how many young girls drank milk.

		Nationwide Food Survey Years			Total
		1987-1988	1989-1991	1994-1996	
Drinks Fluid Milk	Yes	354	502	366	1222
	No	226	335	366	927
	Total	580	837	732	2149

Based on the data given above, what was the probability that a randomly chosen girl in 1990 drank milk?

A)  $\frac{502}{1222}$

B)  $\frac{502}{2149}$

C)  $\frac{502}{837}$

D)  $\frac{1222}{2149}$

120) The table below gives the result of a survey at a college, asking students whether they were residents or commuters:

—

Student living situations

		Home			Row Summary
		No Response	Resident	Commuter	
Year	No Response	0	0	0	0
	First Year	0	32	4	36
	Sophomore	0	35	5	40
	Junior	0	24	16	40
	Senior	0	13	18	31
Column Summary		0	104	43	147

S1 = `count ( )`

Based on the above data, what is the probability that a randomly chosen commuter student is a junior or a senior?

- A)  $\frac{34}{43}$
- B)  $\frac{34}{71}$
- C)  $\frac{34}{147}$
- D)  $\frac{71}{147}$

121) At a school fundraising event, people can buy a ticket to spin a spinner like the one below. The region that the spinner lands in tells which, if any, prize the person wins.



If 240 people buy tickets to spin the spinner, what is the best estimate of the number of keychains that will be given away?

- A) 40
- B) 80
- C) 100
- D) 120

122) What is the probability that someone who spins the above spinner twice will win a keychain on the first spin and a baseball hat on the second spin?

- A)  $\frac{1}{9}$
- B)  $\frac{1}{12}$
- C)  $\frac{1}{18}$
- D)  $\frac{1}{36}$

123) If two fair coins are flipped, what is the probability that one will come up heads and the other tails?

A)  $\frac{1}{4}$

B)  $\frac{1}{3}$

C)  $\frac{1}{2}$

D)  $\frac{3}{4}$

## Answer Key

1	B
2	A
3	D
4	B
5	B
6	D
7	A
8	C
9	A
10	B
11	B
12	D
13	D
14	C
15	C
16	A
17	C
18	C
19	A
20	C
21	B
22	A
23	D
24	D
25	C

26	D
27	D
28	C
29	D
30	A
31	B
32	D
33	A
34	D
35	D
36	C
37	C
38	D
39	B
40	A
41	A
42	B
43	D
44	B
45	A
46	C
47	C
48	A
49	A
50	D

51	C
52	B
53	A
54	C
55	D
56	A
57	B
58	C
59	D
60	B
61	C
62	A
63	D
64	B
65	C
66	B
67	D
68	D
69	D
70	A
71	B
72	D
73	B
74	C
75	C

76	B
77	C
78	D
79	A
80	B
81	B
82	B
83	C
84	A
85	A
86	B
87	B
88	D
89	A
90	B
91	C
92	C
93	A
94	D
95	D
96	D
97	B
98	A
99	C
100	B

101	C
102	C
103	B
104	A
105	A
106	B
107	C
108	C
109	B
110	C
111	D
112	B
113	A
114	C
115	B
116	C
117	A
118	D
119	C
120	A
121	B
122	C
123	C